



ADDENDUM

Date: **October 19th, 2022**

Subject: **PLCB - DISPLAY RACKS**

IFB Number: **270008**

Due Date/Time: **November 11th, 2022 / 1:00 P.M.**

Addendum Number: **1**

To All Offerors:

A solicitation "Addendum" is defined by the Commonwealth of Pennsylvania as an addition to or amendment of the original terms, conditions, specifications, or instructions of a procurement solicitation (e.g., Invitation to Bid, Request for Proposals or Request for Quotations).

List any and all changes:

- Attached are questions received as of 1:00 P.M. October 12th, 2022, along with the PLCB's responses.

If you have already submitted a bid to the original solicitation, you may either submit a new response, or return this Addendum with a statement that your original response remains firm, by the due date to the above address.

Except as clarified and amended by this Addendum, the terms, conditions, specifications, and instructions of the solicitation and any previous solicitation addenda, remain as originally written.

Respectfully,

Name: Brian Thompson
Title: Issuing Officer
Phone: 717-787-9853
Email: brianthom@pa.gov

PLCB – DISPLAY RACKS

IFB 270008

Questions and Answers

Q1. Are further details available regarding the plastic bin pack out, such as a detailed listing of quantity, dimensions? Also, in the image, what are the items shown to the left and right of the bins as part of the pack out?

A1.

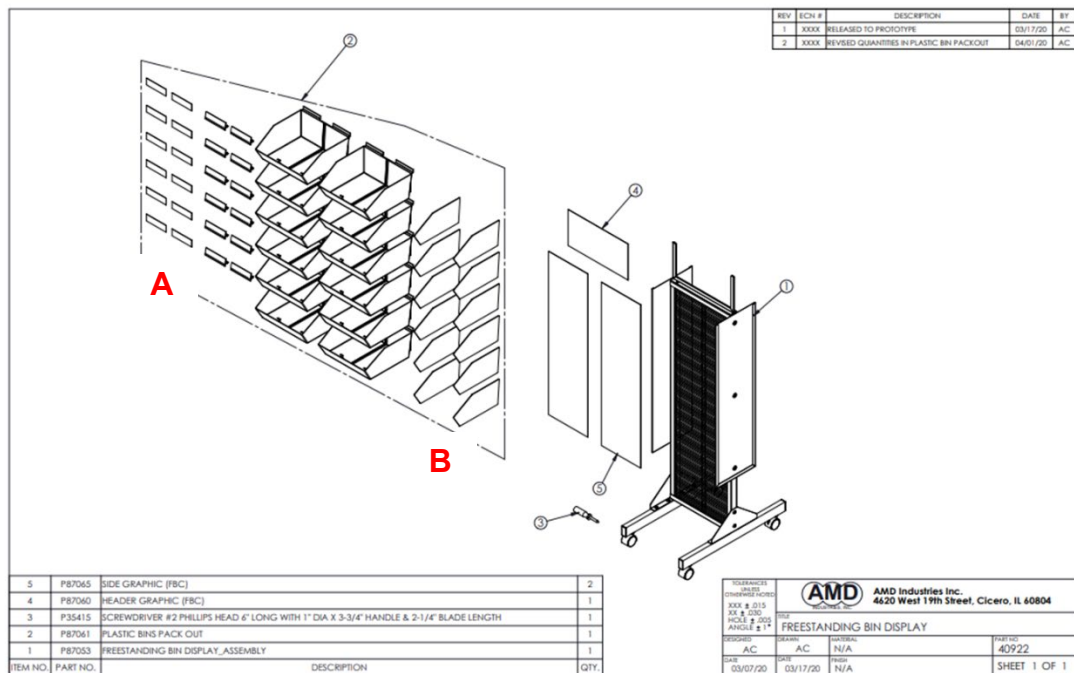

We will need 12 bins that can be separated into 24 bins. The size of the bins cannot exceed the size of the back panel and it will need to fit 6 bins each side. The items to the left (A) are the plastic price tag holders. The items to the right (B) are the dividers to make the 12 bins into 24.

Q2. The IFB states a delivery date of 4 weeks after receipt of order. Is there any flexibility in this timing?

A2. No, we would like to get these into stores as soon as possible.

Q3. Are we responsible for trash removal? And will there be dumpster onsite?

A3. Please refer to IFB 270008 Specifications, pages 6 and 7 – this is a “one time” order for approximately 382 Display Racks to be broken down and shipped to three separate PLCB Facilities Maintenance Shops. The selected offeror will not be responsible for trash removal as this IFB is for delivery of display racks only.

Q4. Will there be anyone else in the workspace that my guys would need to share with?

A4. Please refer to IFB 270008 Specifications, pages 6 and 7 – this is a “one time” order for approximately 382 Display Racks to be broken down and shipped to three separate PLCB Facilities Maintenance Shops. Sharing of a workspace is not applicable to this IFB as it is for delivery of display racks only.

Q5. How many hours will they have to complete the job in a day?

A5. Please refer to IFB 270008 Specifications, pages 6 and 7 – this is a “one time” order for approximately 382 Display Racks to be broken down and shipped to three separate PLCB Facilities Maintenance Shops. Delivery is expected no later than four weeks from receipt of a PO.

Q6. Should there be partitions at the front and back of the racks?

A6. Yes, they hold the plastic bins.

Q7. Do you have the specific size of the partition? Do you need advertising stickers on the partition? Is there a replaceable banner in front of the partition?

A7.

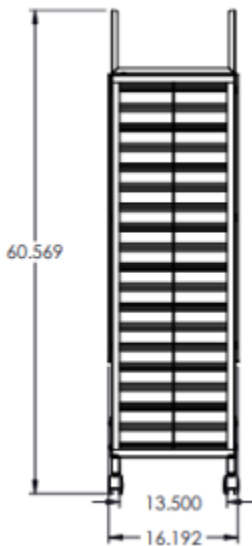

The size is above. Unit of measure is inches. There is not advertising needed on the partition, or a replaceable banner on the partition.

Q8. How much weight does a single partition need to bear? Or how much weight does the whole shelf have to bear?

A8. A single side should hold about 50 pounds, each bin should hold 3 to 4 pounds.

Q9. Would you please give me some picture? It would be better to have a reference brand.



A9.

Q10. Could you provide the budget or the last award unit price?

A10. Historical pricing is immaterial to this solicitation. A contract will be awarded to the bidder that can provide the lowest cost to the PLCB.